

# Themis manual

BOOKOO THEMIS MINI SCALE is designed specifically for espresso extraction. This scale provides exceptional precision and sensitivity, complemented by a range of features designed to enhance and surprise your coffee experience.

Disclaimer: This coffee scale is a high-precision weighing device. Please adhere to the instructions outlined in the manual. This product's warranty does not cover damage caused by improper use.

# Specification

---

Product Name	BOOKOO THEMIS MINI ESPRESSO SCALE
Product Model	SCMINI-01
Product Weight	Approximately 140g
Product Dimensions	W80mm * L80mm * H15mm
Use temperature	0-40°C
Maximum Capacity	1000g
Minimum Capacity	0.1g
Resolution	0.1g
Charge	TYPE-C cable
Charging Power	5V1A
Battery Capacity	500mAh
Main Material	6063 Aluminum Alloy, AF Coated Tempered Glass, Food-grade Silicone

## 1. Basics

- Remove the transparent plastic protective seal from the back of the electronic scale before initial use.
- Long-press the left button to power on/off the device. Upon powering on, the Bluetooth name of the device will be displayed.

- Long-press the right button to switch between modes. One white light indicates flow rate mode, two white lights indicate timer mode, and three white lights indicate automatic mode.

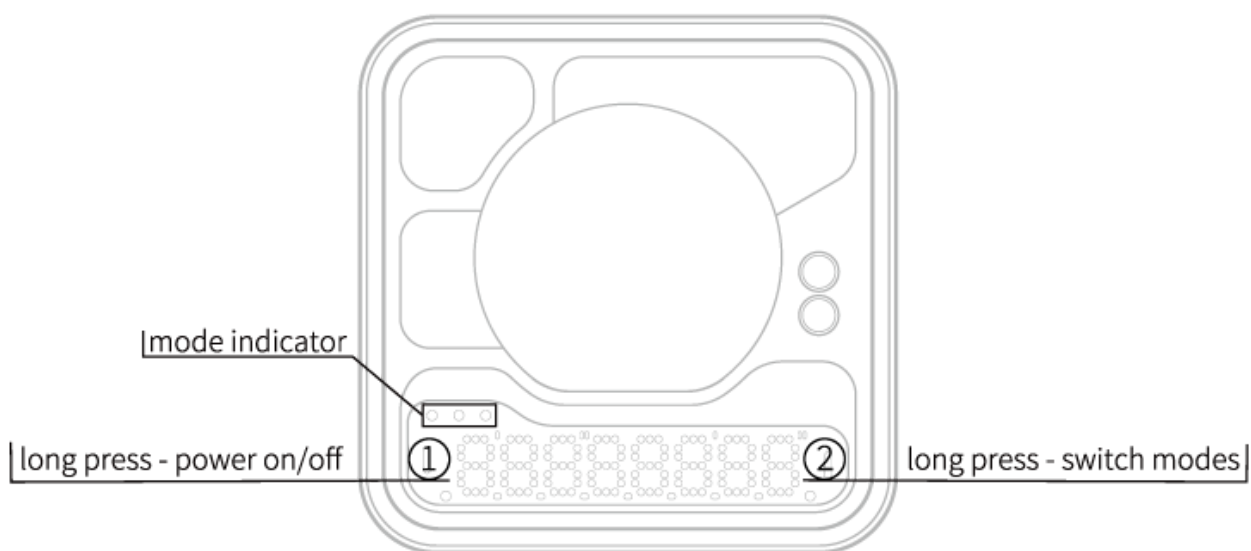

## 2. Mode Descriptions

- Mode 1: Flow Rate Mode
  - The left side displays the flow rate; the right side displays the weight.
  - The left button: no effect
  - The right button: short press - tare

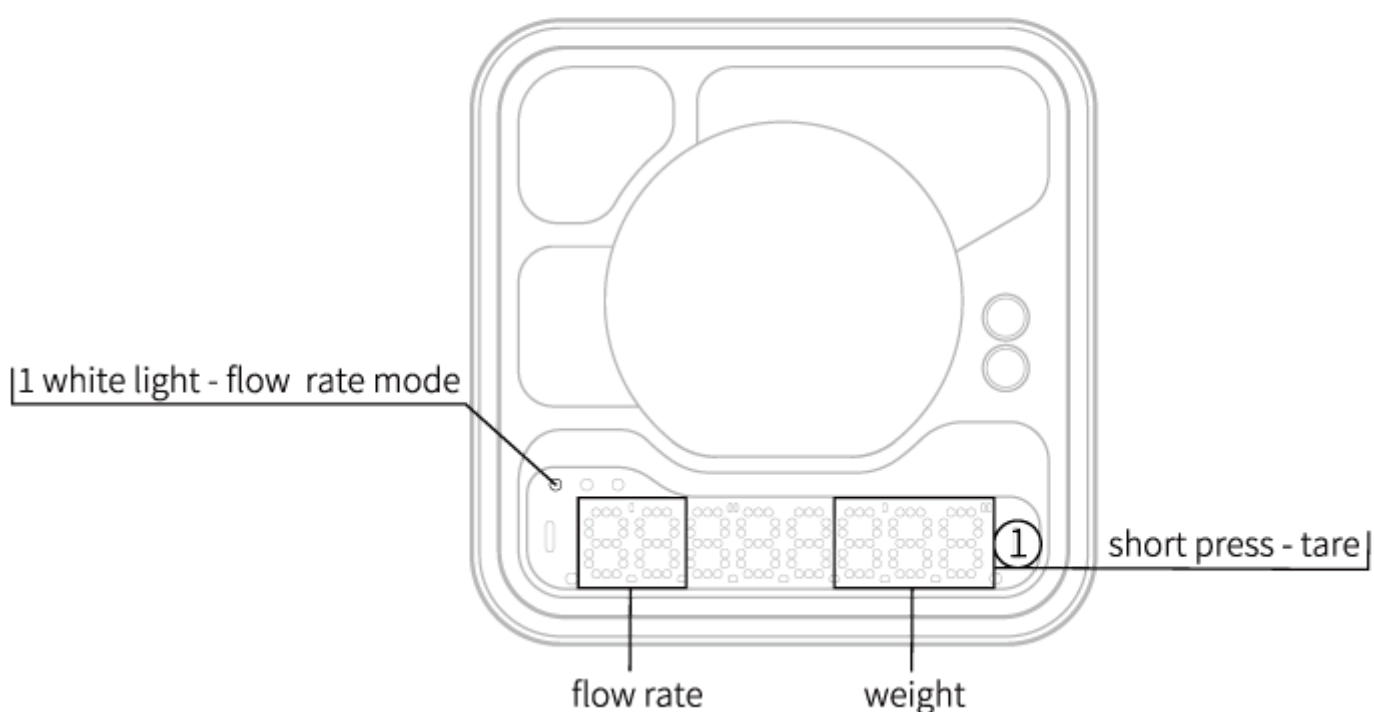

- Mode 2: Timer Mode
  - The left side displays the time; the right side displays the weight.

- The left button: short press - starts, stops, or resets the timer
- The right button: short press - tare

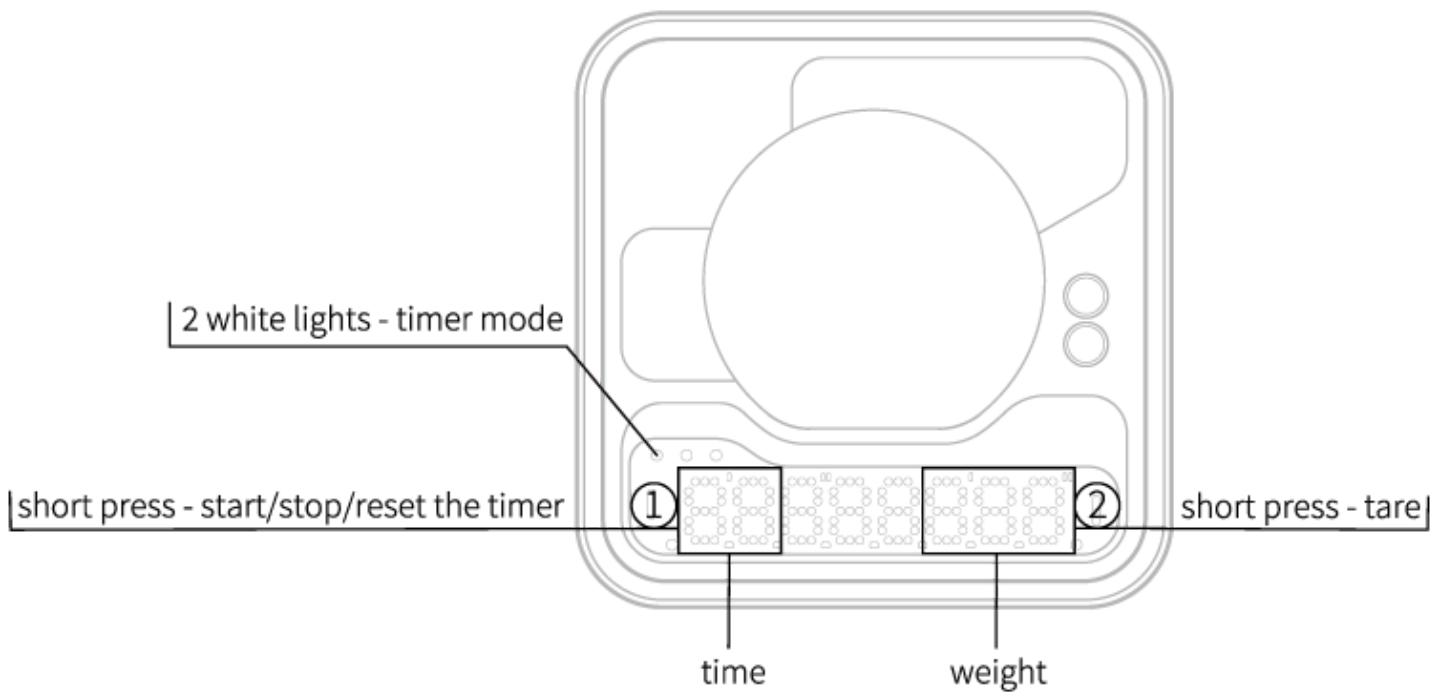

- Mode 3: Automatic Mode

- The scale automatically tares upon placing a cup, waiting for extraction.
- Timing starts upon liquid detection, with time on the left and weight on the right.
- To end the extraction:
  - Option 1: End the extraction by removing the cup, with the time display stopping when the flow rate reaches zero.
  - Option 2: Manually end the extraction by pressing the left button briefly, with the time display stopping at the moment the button is pressed.
- After extraction, the left side alternates between displaying the extraction time and average flow rate, while the right side shows liquid weight.
- Tap the right button to the next extraction.
- In case of unexpected situations, double-click the right button to force exit the current extraction.

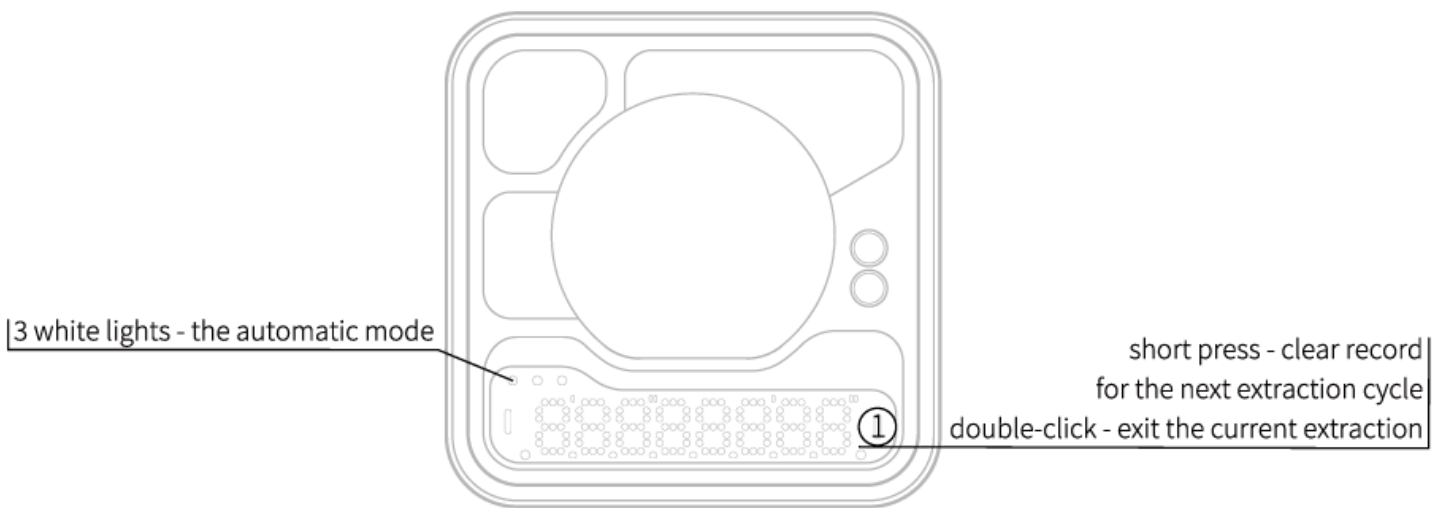
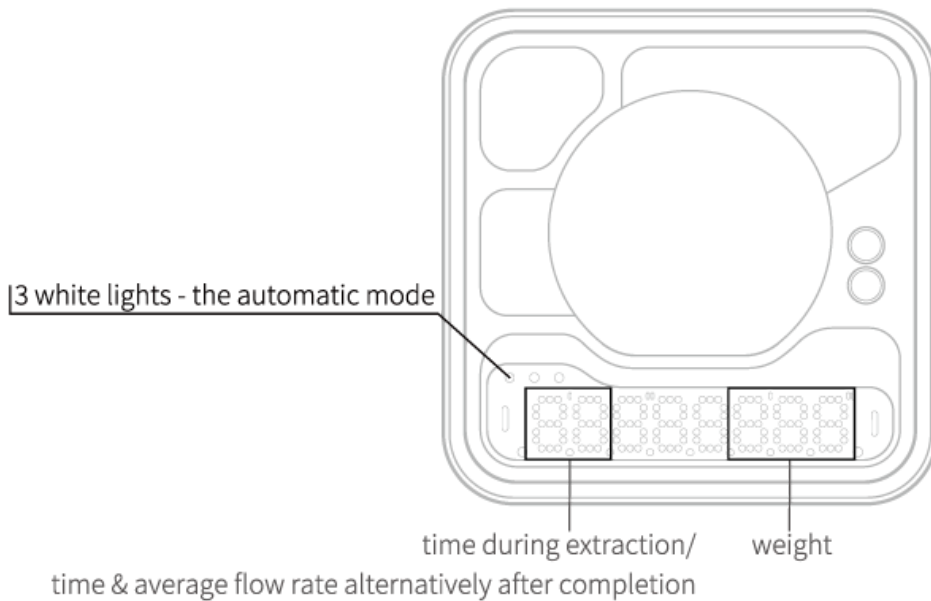

### 3. APP

- Download

Search for "BOOKOO" in app stores for iOS and Android to download the application, or visit <https://app.bookoocoffee.cn> to download the app.

- Updates

「Menu-Setup- Version Management- Current App Version」 A red update prompt will be displayed if the new version is available.

- More Settings

「Menu-Setup」 You can personalize various settings and access information queries according to your preferences.

### 4. Bluetooth Connection

- Permission Settings

Upon first use of the app, please grant the necessary Bluetooth permissions to the app.

- Connection Methods

- Pop-up Connection: The app is set to open a pop-up for connection by default.
  - Auto Connection: 「Menu - Setup - Basic - Device Settings - Automatic Connection」 When enabled, the app will automatically connect to the Bluetooth device upon opening.
  - Manual Connection: By clicking the corresponding icon, you can enter the connection page, search for devices by pulling down the list, and click on the Bluetooth name to establish a connection.
  - Connection Status Display
    - Once Bluetooth is connected, the left-side blue light will turn on, indicating a successful Bluetooth connection.
- ## 5. Weight Calibration
- Calibration Method
    - In *Flow Rate Mode*, quickly press the right button 8 times to initiate the calibration mode, or access the 'BOOKOOSC Online Calibration' option through the Bluetooth device connection interface. Once the screen displays 'PULL,' place a 100g calibration weight on the scale. When the screen shows 'PASS,' it indicates that calibration is complete.
  - Note
    - The scale is calibrated at the factory. If you need to adjust the calibration value, please use F1 class weights that meet the JJG99-2006 standard for calibration to avoid measurement deviations.
    - Before calibration, ensure that the scale is placed on a level and stable surface.
- ## 6. Other
- You can access additional settings in the app, such as system language, buzzer sound (default: enabled), auto sleep time (default: 15 minutes), and more.

## Indicator Light Guide

---

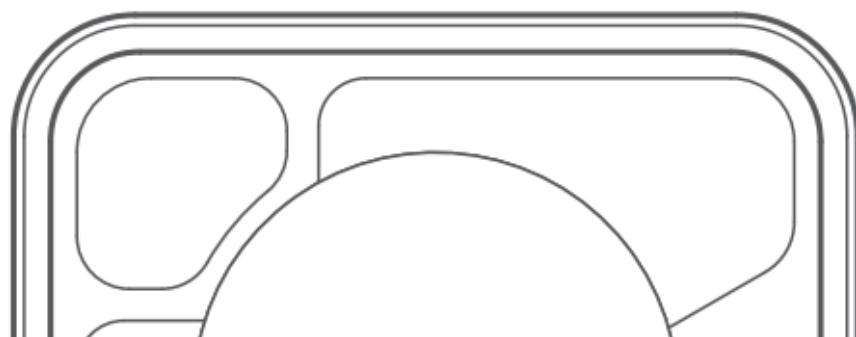

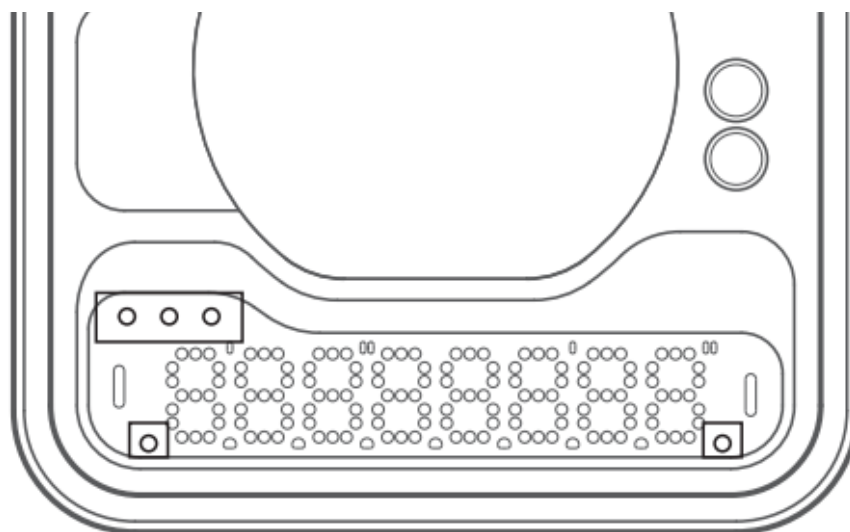

Indicator Light Guide	Details
Left blue light	Bluetooth connected
Right red light	Low battery reminder
1 white light	Flow rate mode
2 white lights	Timer mode
3 white lights	Auto mode
Alternating flashing of lights	Taring in progress
3 red lights flashing	Charging in progress. (Removing power will show battery level.)

#### Note

- This coffee scale is a high-precision weighing instrument. Damages caused by exceeding the maximum capacity or prolonged overloading are not covered under warranty.
- During transportation and handling, avoid prolonged compression that could affect the accuracy of the scale.

- Do not place magnets, metal objects, or other items that may interfere with the Bluetooth signal near the scale, as it may result in a weakened or lost Bluetooth connection.
- Use F1 class weights for calibration to maintain the highest accuracy and optimal performance.
- Avoid prolonged exposure to hot or cold water showers and direct steam, as it can damage the circuitry and even result in safety hazards such as short circuits or combustion.
- Do not use the scale in environments outside the temperature range of 0-40°C, as it may damage the product's performance and lifespan.
- The scale's surface is waterproof, but be cautious to prevent liquids from entering the gaps in the body and the charging port.

## Warranty Policy

Thank you for purchasing our Themis Mini Scale. We are committed to providing high-quality products and offer the following warranty policy for your purchase:

- The warranty period is one year from the date of purchase.
- The warranty covers failures caused by manufacturing defects or material issues. The warranty does not cover the following: damages caused by human factors, misuse, or accidents; unauthorized repairs or modifications; failures resulting from natural disasters, fires, floods, or other force majeure events.
- If a failure occurs within the warranty period, please follow the steps below to obtain warranty service:
  - Contact our customer service team and provide your purchase receipt, purchase information, product serial number, and the situation description.
  - We will guide you through the necessary troubleshooting steps. If remote support cannot resolve the issue, we may ask you to send the product to our repair center.
  - After evaluation, if the failure is non-human-caused, we will provide free repair or replacement of the product.
- Additional Notes:
  - Repairs or replacements within the warranty period will not extend the original warranty.
  - For failures caused by human factors or issues that arise after the first year of warranty, you can contact us for support. We will do our best to assist you in resolving the problem. Please note that repair services may incur certain fees depending on the severity of the damage.



- The above warranty policy applies only to our Themis Mini Scale product and may vary based on the country/region you are in. For more detailed information or any inquiries, please contact our customer service team. We are dedicated to providing assistance and answering your questions.